

Contact Rating

- Nominal Load(Resistive Load Cos $\phi = 1$)
Contact Capacity
BSZ6-L/LM.....3A at 125VAC
3A at 24VAC
- Max. Allowable Current
BSZ6-L/LM.....3A
- Max. Allowable Voltage
BSZ6-L/LM.....AC125V,DC24V
- Max. Allowable Power Force
BSZ6-L/LM.....375VA 72W
- Contact Material..... Ag Alloy
- Contact Form..... SPDT & SPST

Performance (at Initial Value)

- Contact Resistance..... $\leq 50m\Omega$ at 6VDC/1A
- Operate Time.....10ms. Max
- Release Time..... 5ms. Max
- Dielectric Strength:
Between Coil & Contact.....1,000VAC at 50/60 Hz
for one minute
Between Contacts.....500VAC at 50/60 Hz
for one minute
- Surge Resistance.....1,500V (between Coil
& Contact 1.2x50 μ s)

Main Feature

1. Small size (15.5x10.5x11.2 in mm) produces a switching capacity up to 3A for high density P.C.Board mounting technique.
2. The contact form construction is 1A/1C
3. The Surge Resistance of BSZ6 series is 1,500V
4. Sealing Construction (Free from dust and solder flux):
BSZ6-SS: Plastic Sealed Type.
5. The selection of plastic insulation material is designed for high temperature and provides better chemical solution performance.
6. RoHS Compliant.

Application

Air Conditioning, Fridge, Washing Machine, etc Household Appliances

- Insulation Resistance.....1,000Mega Ω Min. at
500VDC
- Max. On/Off Switching:
Electrical.....30 Ops per minute
Mechanical.....300 Ops per minute
- Temperature Range..... - 30~70°C
- Humidity Range.....5%~85% RH
Coil Temperature Rise..... 35°C Maximum
- Vibration:
Endurance.....10 to 55 Hz dual
amplitude width 1.5mm
Error Operation.....10 to 55 Hz dual
amplitude width 1.5mm
- Shock:
Endurance..... 981m/s² Min
Error Operation..... 98.1m/s² Min
- Life Expectancy:
Electrical.....10⁵ Operations at
Rated Resistive
load
Mechanical.....10⁷ Operations at
No load condition
- Weight.....about 3.5g

Safety Standard & Its File Number

- UL.....Pending

Coil Specification (at 20 °C)

| Coil Sensitivity | Nominal Voltage (VDC) | Nominal Current (mA) | Coil Resistance ($\Omega \pm 8\%$) | Power Consumption (W) | Pull-In Voltage (VDC) | Drop-Out Voltage (VDC) | Maximum Allowable Voltage (VDC) |
|------------------|-----------------------|----------------------|--------------------------------------|-----------------------|-----------------------|------------------------|---------------------------------|
| BSZ6-L/LM | 3 | 66.7 | 45 | Abt. 0.2 | 75% Maximum | 10% Minimum | 130% |
| | 5 | 40 | 125 | | | | |
| | 6 | 33.7 | 180 | | | | |
| | 9 | 22.2 | 405 | | | | |
| | 12 | 16.7 | 720 | | | | |
| | 24 | 8.3 | 2880 | | | | |

Ordering Information

| | | | | | | | | |
|-------------|----------|-----------|----------|----------|-----------|----------|----------|-----------------------------------------------------------------|
| BSZ6 | - | SS | - | 1 | 12 | L | M | |
| | | | | | | | | Contact Form: Nil:One form C M:One form A |
| | | | | | | | | Coil Type: L:Standard DC Coil |
| | | | | | | | | Coil Voltage: 03:3V, 05:5V,06:6V, 09:9V12:12V,24:24V. |
| | | | | | | | | Number of Pole: 1:One Pole |
| | | | | | | | | Type of Sealing: SS:Plastic Sealed Type |
| | | | | | | | | Type: BSZ6 |

Classification

| Model | BSZ6 | |
|------------------|------------------|---------------|
| Coil Sensitivity | Standard DC Coil | |
| | 1C | 1A |
| Flow Solder Type | BSZ6-SS-1□□L | BSZ6-SS-1□□LM |

Dimension

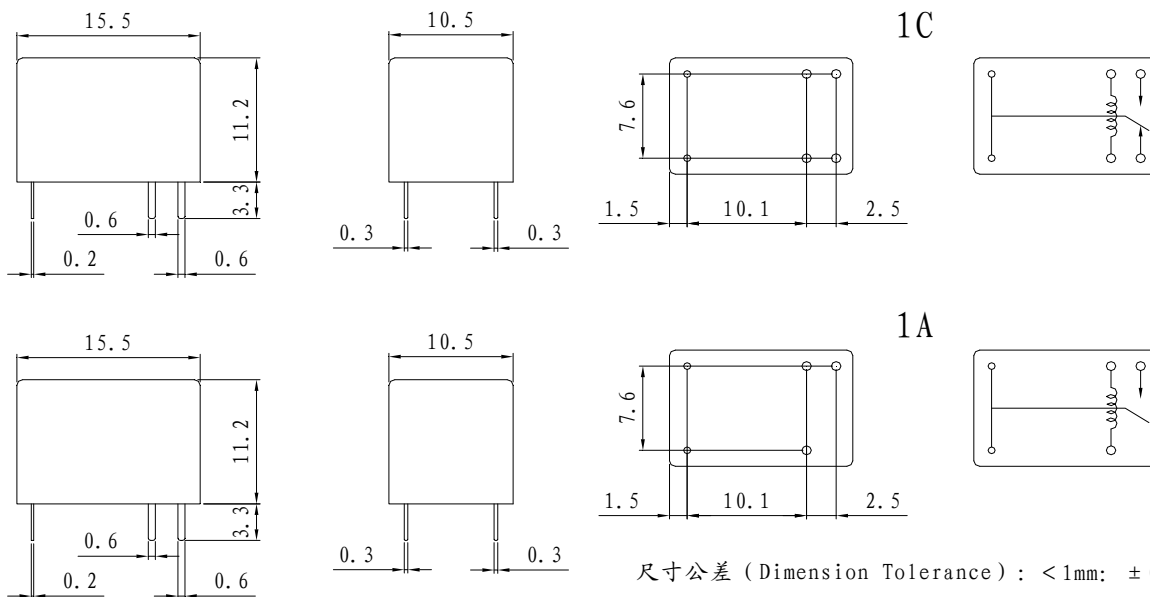

尺寸公差 (Dimension Tolerance) : < 1mm: $\pm 0.2\text{mm}$
 1--5mm: $\pm 0.3\text{mm}$
 > 5mm: $\pm 0.5\text{mm}$